

OBEX LINE N1

Aluminium bridge parapet - 1,0 m high

Tested and certified according to EN 1317

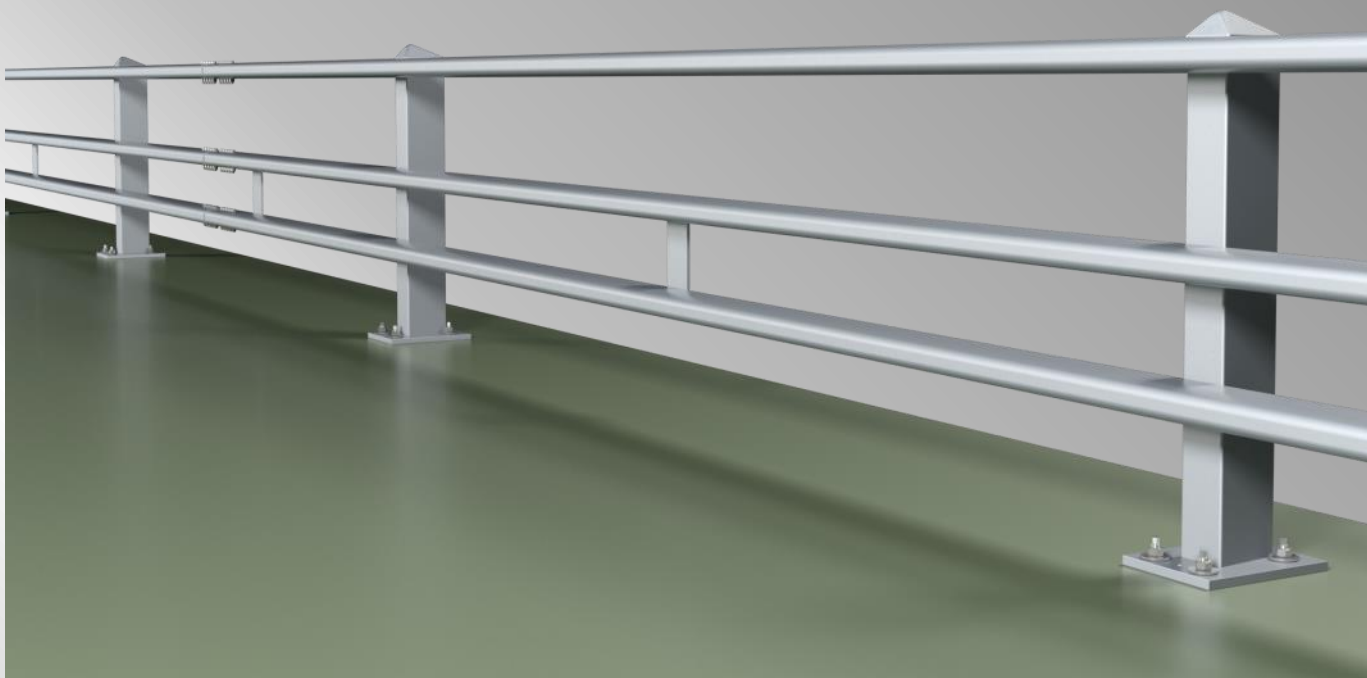

OBEX Systems Ltd.

Vehicle containment specialist for
a global market.

www.obexsystems.com



OBEX LINE 4.0B 3R

Aluminium bridge safety barrier class N1



OBEX LINE 4.0B 3R

Aluminium bridge safety barrier class N1

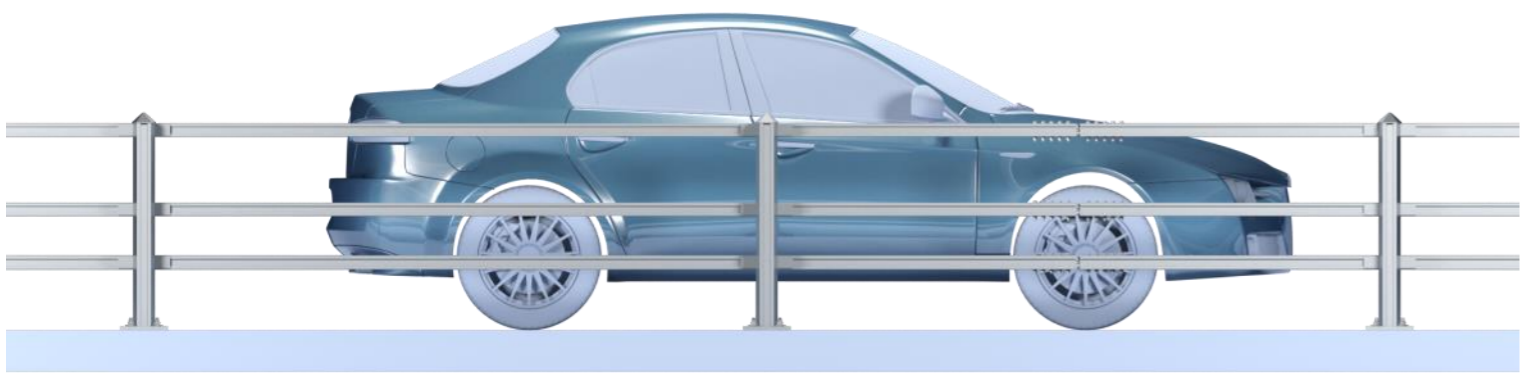

ASSEMBLY VIEW

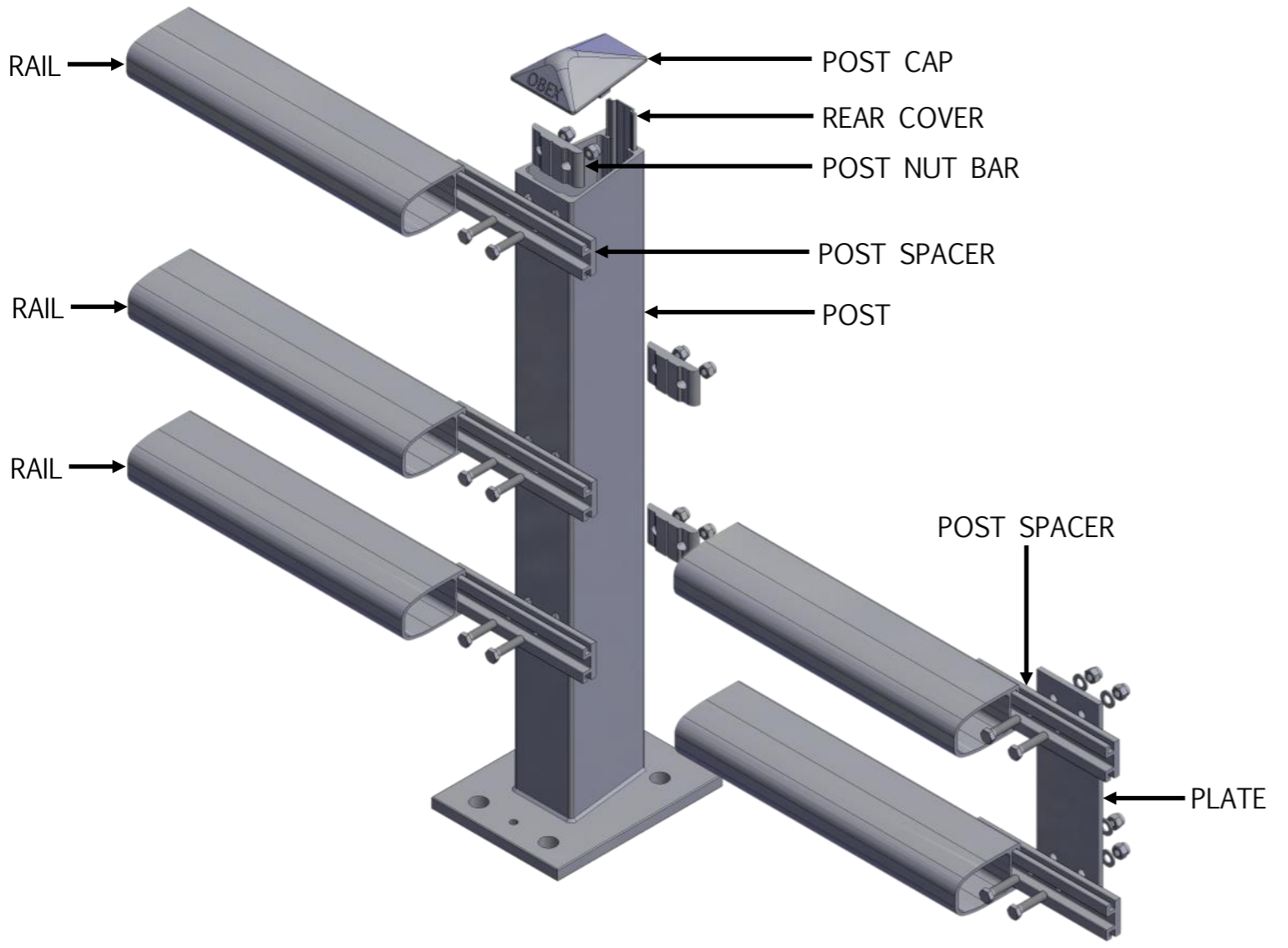

FRONT VIEW

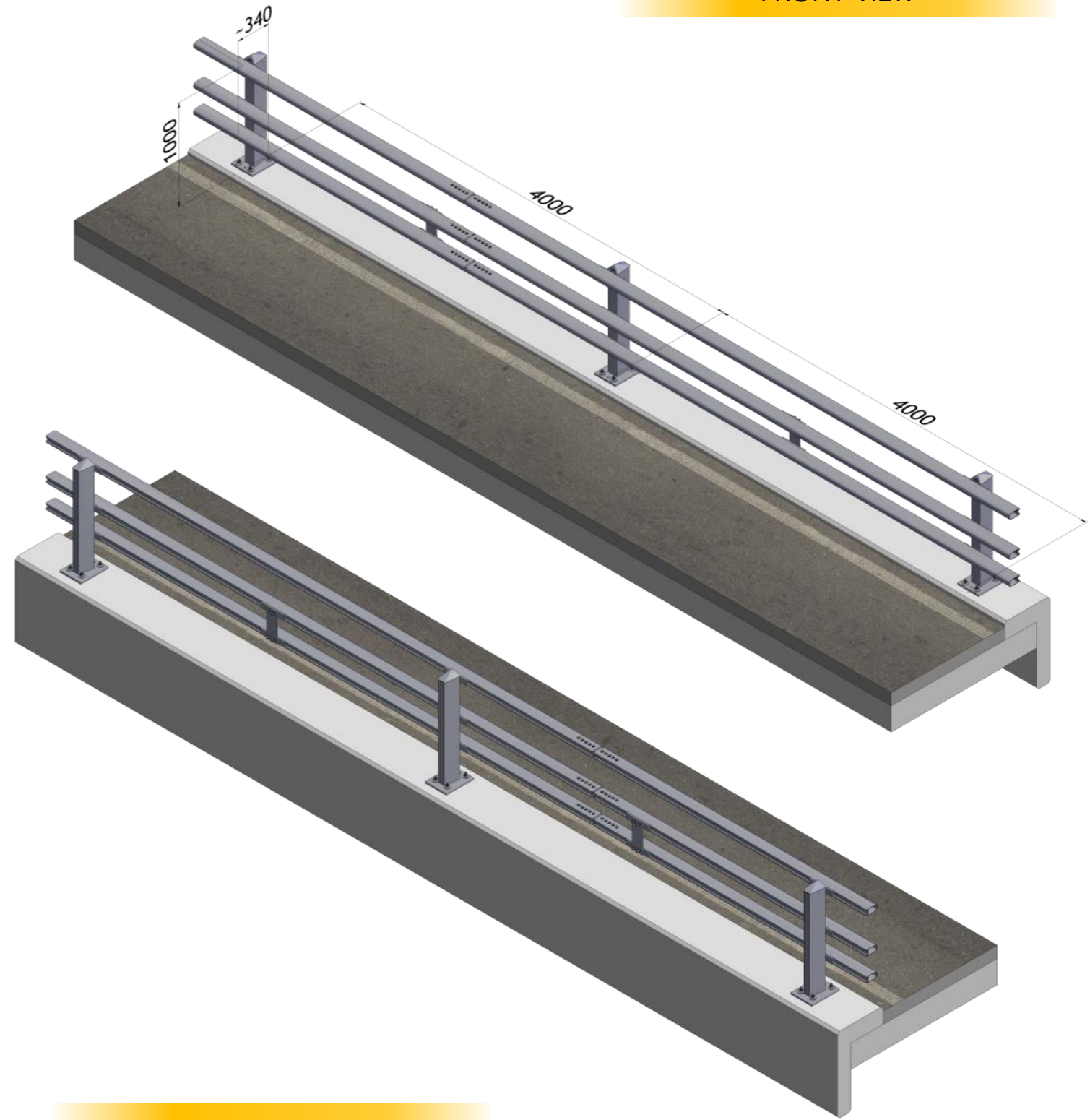

REAR VIEW

OBEX LINE 4.0B 3R

Aluminium bridge safety barrier class N1

ANCHORING OPTIONS

ACCESSORIES

OBEX LINE 4.0B 3R

Aluminium bridge safety barrier class N1

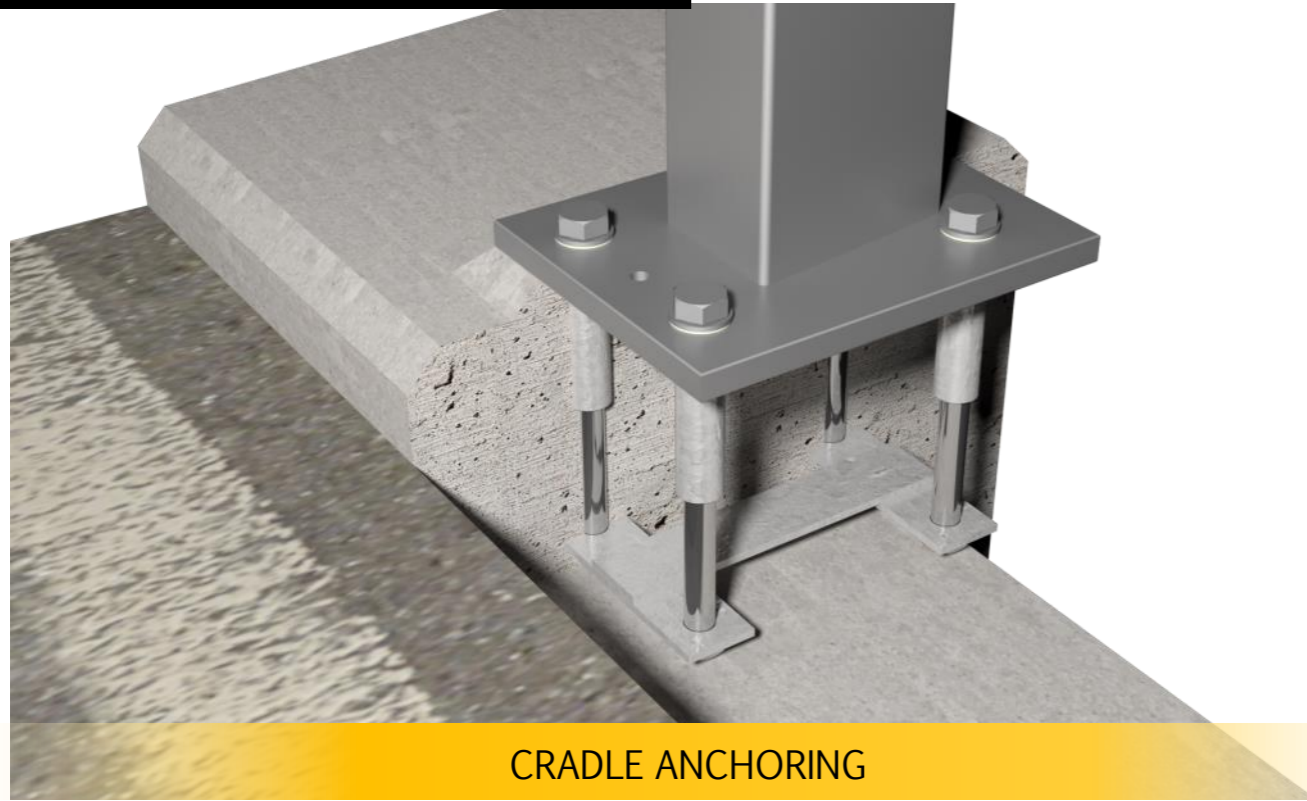

CRADLE ANCHORING



EXPANSION JOINT

THREADED BAR ANCHORING

TRANSITION

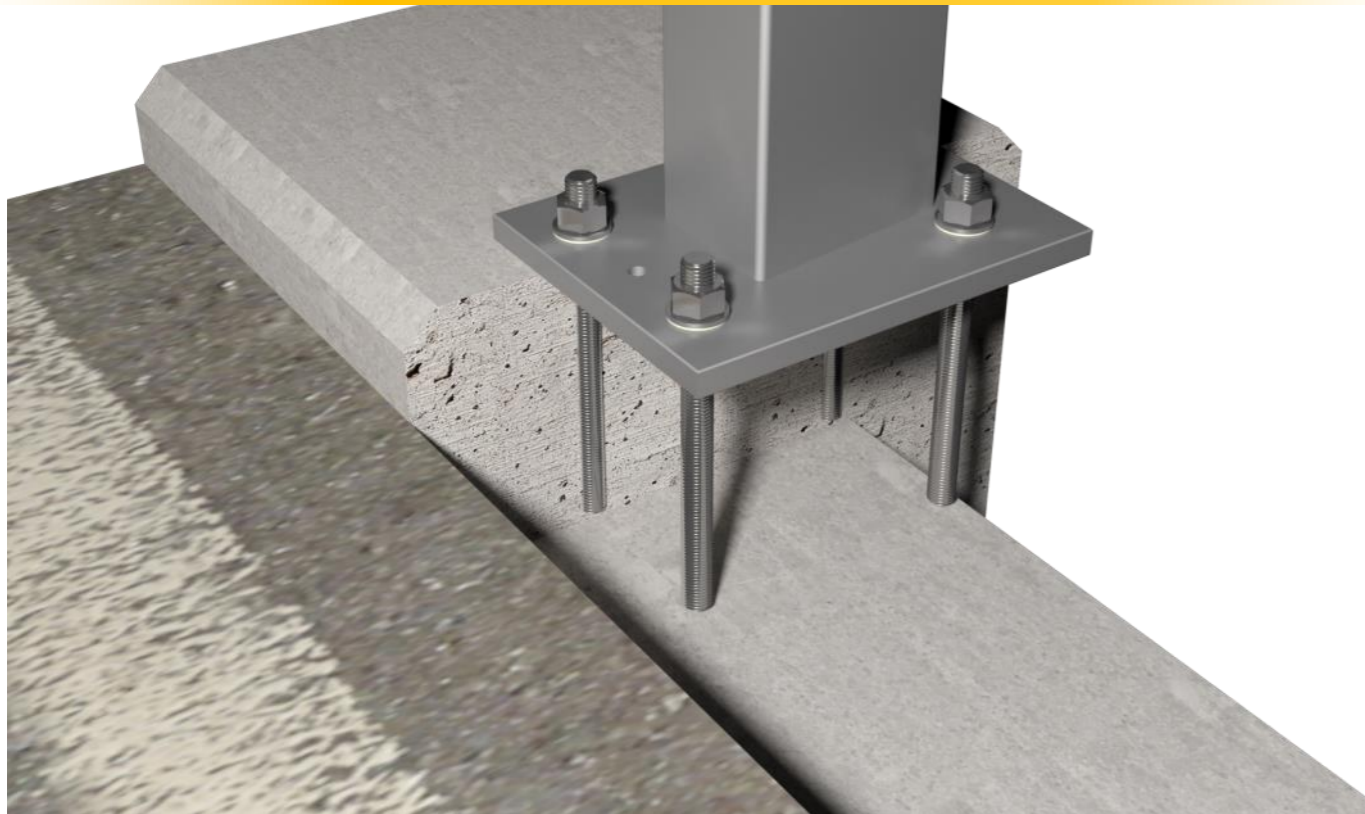

VEHICLE IMPACT TEST (EN 1317)

CRASH TEST

Test TB 31

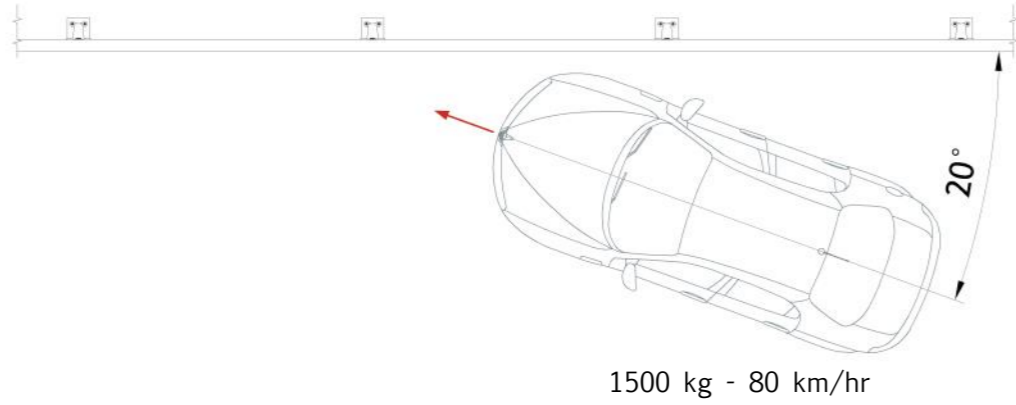

INSTALLATION



PEDESTRIAN PROTECTION



SAFETY BARRIER WITH MESH PROTECTION

OBEX LINE 4.0B 3R

Aluminium bridge safety barrier class N1

PERFORMANCE - N1 (EN 1317)

Test code	Impact Speed	Vehicle Mass	Working Width (W)	Normalised Vehicle Intrusion (VI)	ASI
TB 31	80 km/hr	1500 kg	W1	VI1	A

- The OBEX Line aluminium parapet range is available in **tested & CE certified** configurations as follows:
 - ⇒ N1AW1 – 1.0m high – 3 rail
 - ⇒ N2BW2 – 1.0m high – 3 rail
 - ⇒ N2BW2 – 1.25m high – 4 rail
 - ⇒ H2BW4 – 1.25m high – 4 rail
- Selection of **approved transitions** to complement N1 to H2 design requirements.
- All containment options are **available with increased heights** to facilitate additional pedestrian protection, cycleway and bridleway applications.
- Standard components are used throughout all containment levels allowing for **efficient stock management, repair and upgrade** in containment level if required.
- **Aluminium Alloy** type 6082 T6 is used throughout together with stainless steel fixings and anchors.
- **Excellent corrosion resistance**, maintenance free and lower whole life costs.
- **Minimal load transfer** to the bridge deck on impact allowing for efficient plinth design and flexibility for upgrading works on existing decks.
- **Sector Scheme 5B approved** production.
- **Lantra approved** installation training available.



Obex Systems Ltd
The Distillers Building, New Church Street,
Smithfield, Dublin 7, D07 CXV8, Ireland

T: +353 (0)1 866 5151
E: info@obexsystems.com

